

FOR SAFE OPERATION

- ★ Keep the engine at least 3 ft. away from building or other equipment during operation.
- ★ Do not place inflammable objects such as, gasoline, matches, etc., close to the engine while it is running.
- ★ Operate the engine only on a level surface, otherwise fuel may spill from the fuel tank and engine lubrication may not be sufficient.
- ★ This engine is not equipped with a spark arrestor.
- ★ Operation on forest covered, brush covered, or grass covered land may not be legal in some states. Check local laws and regulations before operation.

WARNING:

- Always stop the engine and do not smoke or allow open flames or sparks near the engine when refueling.
- Do not overfill the tank. There should be no fuel in the filler neck.
- If fuel is spilled, wipe it off completely before starting.
- Make sure that the filler cap is closed securely.

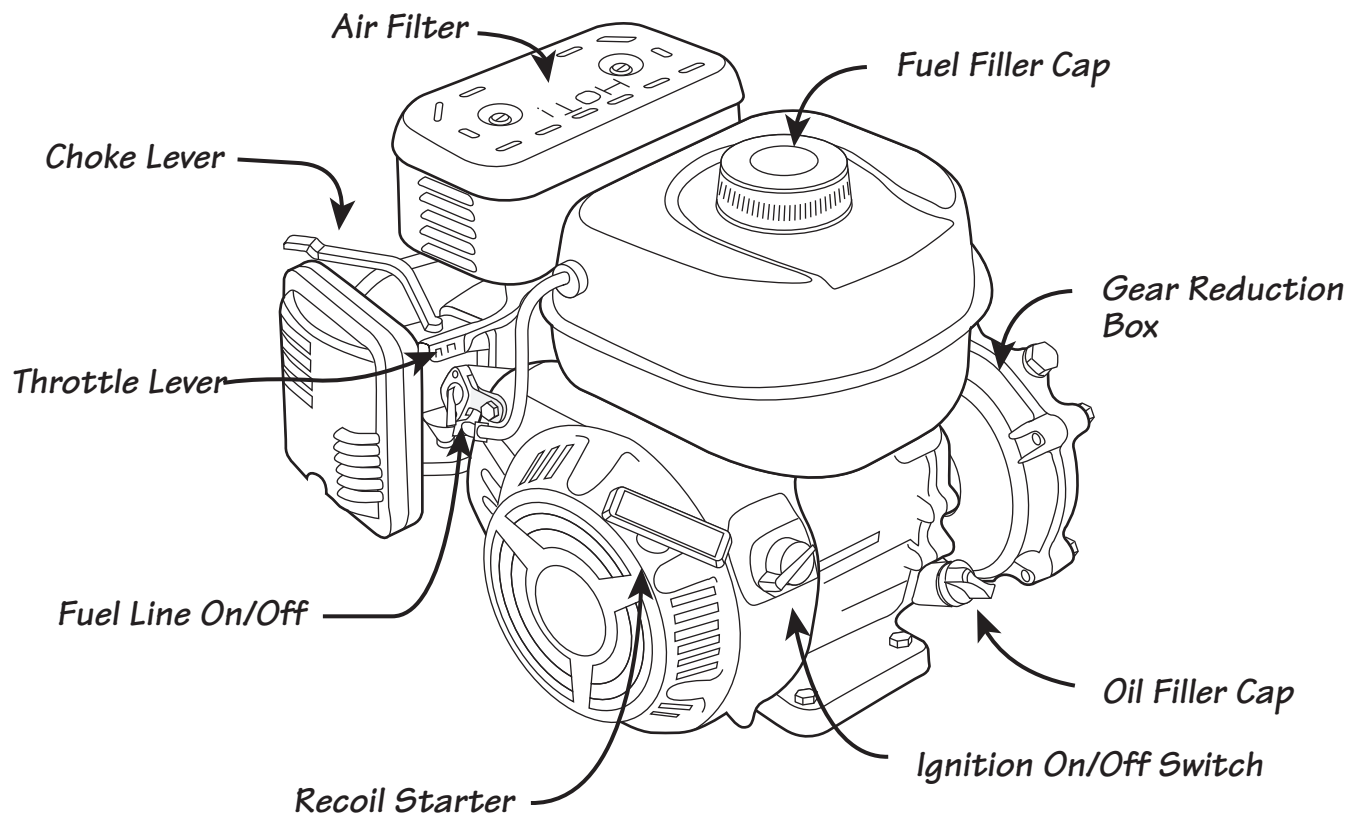

Instruction Sheet #08259

TIE DOWN ENGINEERING • 255 Villanova Drive SW • Atlanta, GA 30336
www.tiedown.com (404) 344-0000 Fax (404) 349-0401



Lifan Engine Operation Check

IMPORTANT! PRIOR TO USE FILL CRANK CASE WITH OIL.

Engine oil recommended: SAE10W-30.

As viscosity varies with regions and temperatures, select the proper engine oil in accordance with the chart below. *Only the gear reduction housing comes pre-oiled!*

Gasoline:

Use gasoline with a Octane level over 86. Using unleaded gasoline will decrease the possibility of producing carbon deposit and prolong the engines service life. Never use a mixture of gas and oil! Make sure the fuel is free of dirt and water.

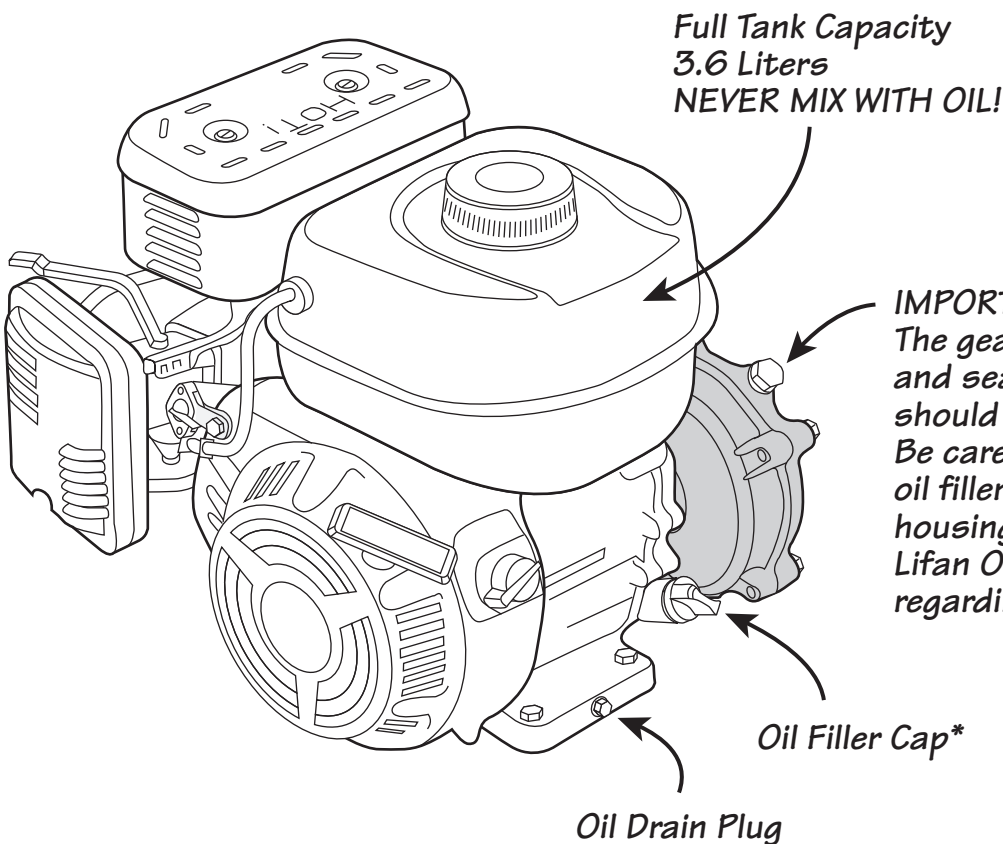
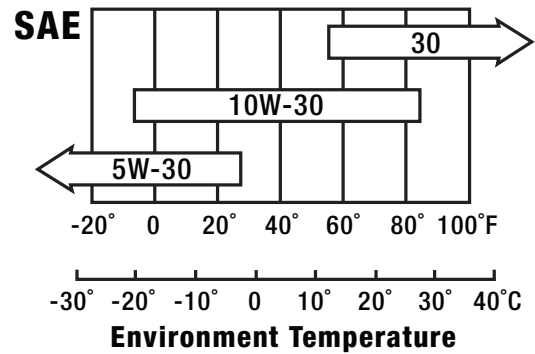

IMPORTANT:

The gear reduction housing is filled and sealed at the factory and should not need any maintainace. Be carefull not to confuse the oil filler cap with the gear reduction housing fill cap. Read the complete Lifan Owners Manual for information regarding the gear reduction housing.

*** NOTE: Engine Oil Alarm (Silent Engine Stall)**

The engine oil alarm is designed to alert the user that the engine oil in the crankcase is insufficient. Once the oil level in the crankcase is too low, the engine oil alarm will stall the engine automatically to make it save from any damage.

Lifan Engine Starting

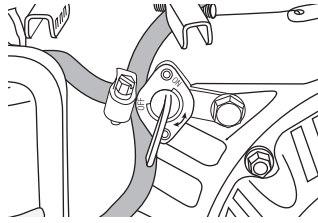

Step 1
Turn the Fuel Line “on/off” valve to the “on” (vertical) position.

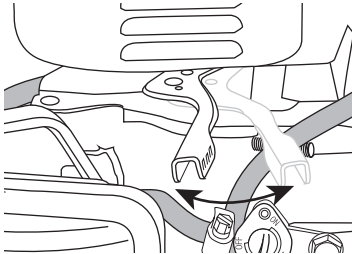

Step 7
Once the motor has been running for 1-2 minutes adjust the Throttle lever for the desired engine speed.

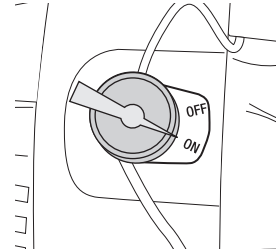

Step 2
Start Up: Turn the “Red” ignition switch to the “On” position.

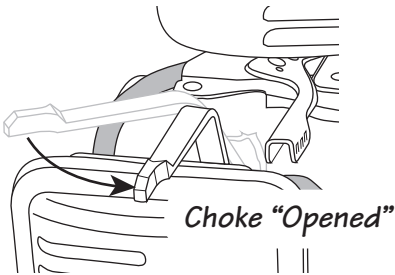

Step 6
Running: With the motor running, open (move to the right) the Choke lever.

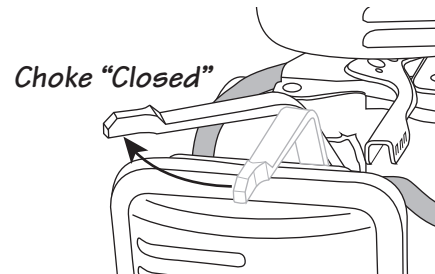

Step 3
Start Up: Adjust the Choke lever to the left, “closed” position.

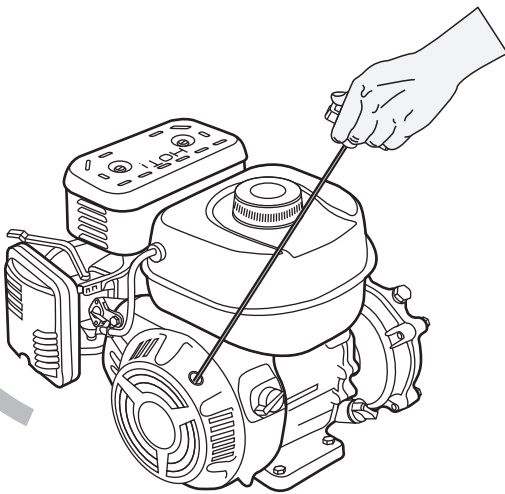

Step 5
Pull starter cord with 3-5 rapid, smooth pulls. The engine will fire and start running.

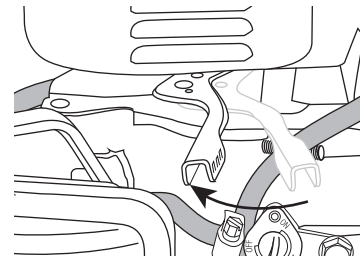

Step 4
Start Up: Adjust the Throttle lever to “half” throttle position.

Lifan Engine Shut Down

Step 1

Turn-off the fuel line “on/off” valve and allow the motor to stop running.

Step 2

Turn the ignition switch to the “off” position. Let the motor cool before attempting to move.

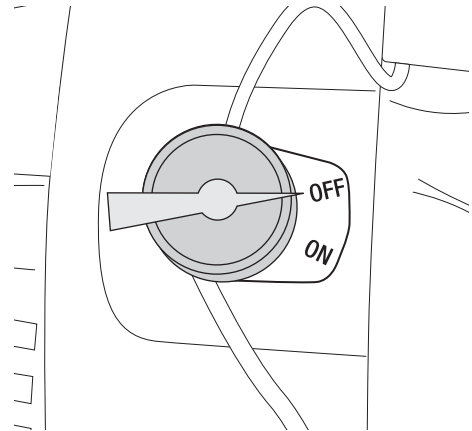
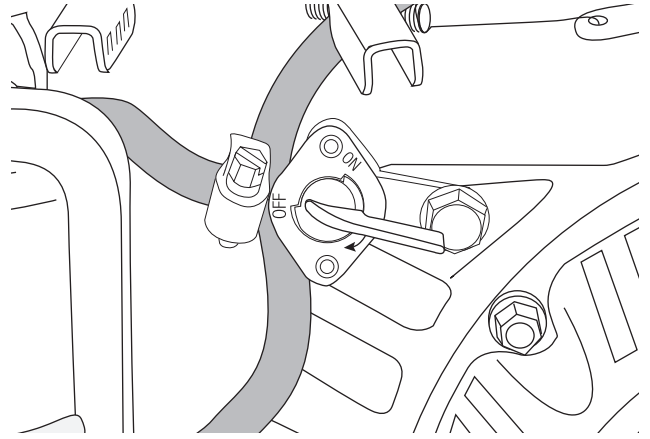

Please refer to the Lifan Owners manual for more information.

**OWNER'S MANUAL
GENERAL GASOLINE ENGINE**

160F-AH 168F-AH 168F-2AH

Roofing Products Division

TIE DOWN ENGINEERING

255 Villanova Drive SW • Atlanta, Georgia 30336

800-241-1806 • 404-344-0000 • Fax 404-349-0401

ISO 9001:2008 Certification

Trade, brand, names and drawings are the intellectual property of

TIE DOWN ENGINEERING. ©2014 TIE DOWN, Inc.

Manual #08259 (Rev. 10-7-15) E1437